

SKAMOTEC 225

FIREPLACE BUILDING BOARD



INSTALLATION MANUAL

TABLE OF CONTENTS

INSTALLATION.....	3
1. Assembling fireplace platform (structure)	3
2. Attaching fireplace platform (top).....	3
3. Positioning fireplace & secure in place	4
4. Installing blocking	4
4.1 Construction of sidewalls.....	4
5. Installing side panels.....	5
6. Installing 2 front bottom panels	6
6.1 Lap joint panel	6
6.2 Fastenening the 2 front bottom panels.....	6
7. Installing front top panel	7
8. Complete installation	7
BLOCKING	8
Lap joint detail.....	9
Preassembling side panels.....	10

INSTALLATION

Cut the Skamotec 225 boards down to size with ordinary wood working tools

Fasten the boards with e.g. drywall screws and mortar cement.

Ventilation should be made according to the specific stove spec. with air intake at the bottom and air outtake at the top.

Be sure to keep a 3 - 5mm distance between the heath source and Skamotec 225.

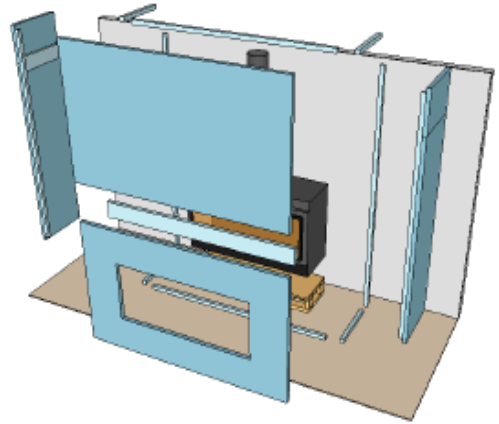

1. Assembling fireplace platform (structure)

Use screws (e.g. drywall screws) to screw the boards together and be sure to maintain a min. edge distance and spacing

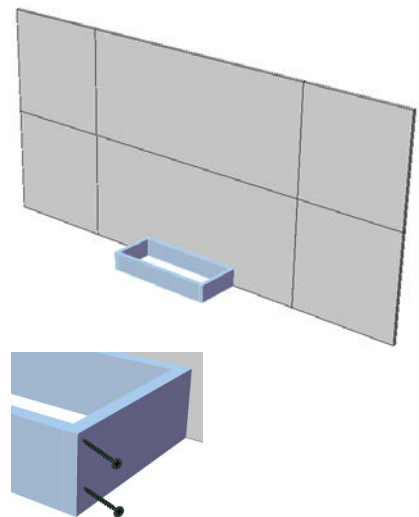

2. Attaching fireplace platform (top)

Fasten the 2 layers of Skamotec 225 using screws

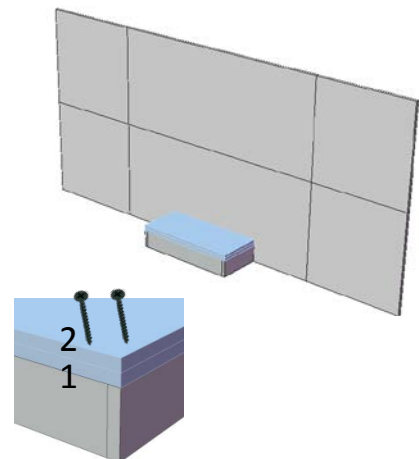

3. Positioning fireplace & secure in place

Make sure to place the fireplace level and square.

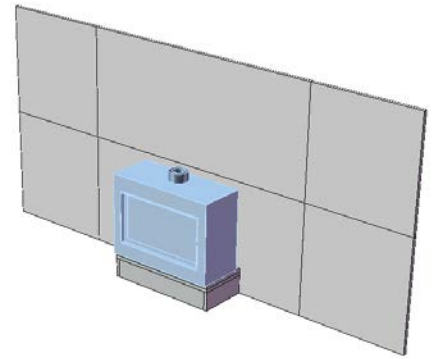

4. Installing blocking

Use 25 x 38 mm Blocking on floor and ceiling
and use e.g. wood screws to fasten them to the floor and
ceiling.

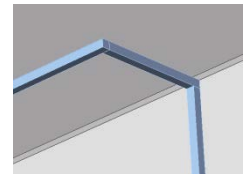
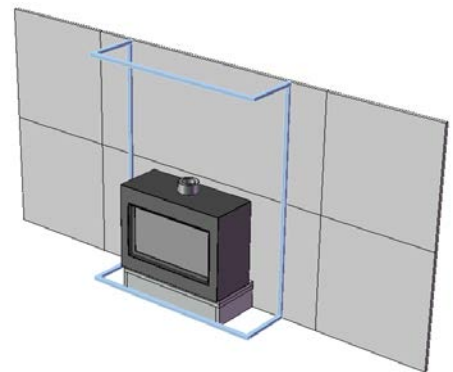

4.1 Construction of sidewalls

Moisten the surfaces of the Skamotec boards with water
and apply mortar cement to the joints in order to glue the
boards together.

Use lap joints

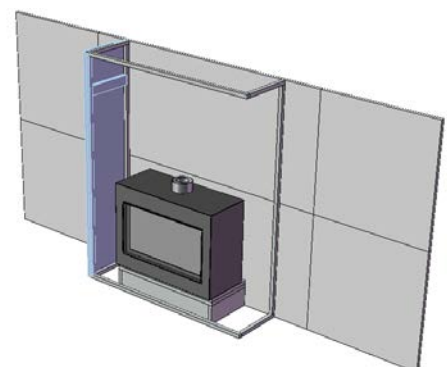

Ceiling:

Place the Skamotec 225 against the blocking and fasten it by using both screws and mortar cement. Maintain a min. edge distance and spacing

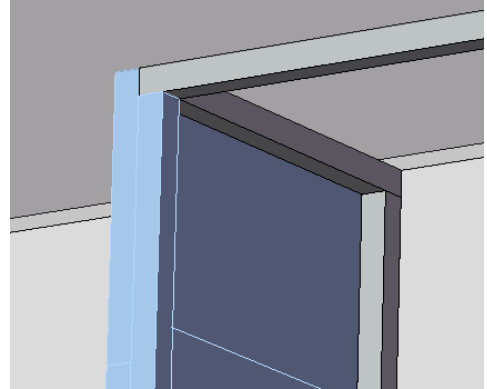

Floor:

Step 1: Place the Skamotec 225 board against the blocking and fasten using both screws and mortar cement. Maintain a min. edge distance and spacing

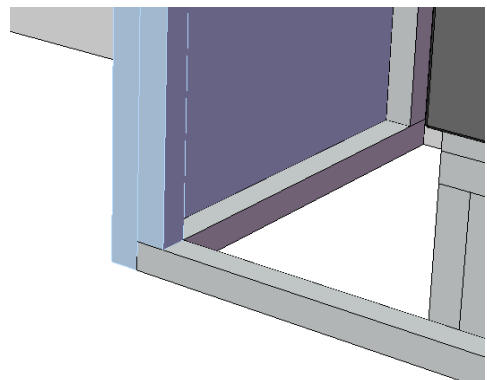

5. Installing side panels

Moisten the Skamotec 225 board surface with water before applying mortar cement

Look at page 8, 9 and 10 for further fastener details and how to preassemble the side panels if the Skamotec 225 boards

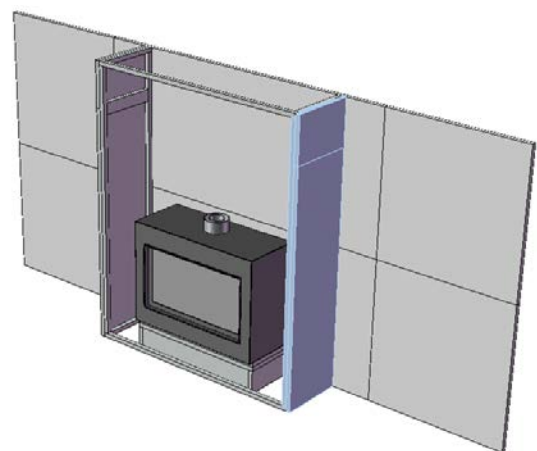

6. Installing 2 front bottom panels

Moisten the surface of the Skamotec 225 with water before applying mortar cement
Look at page 8 and 9 for further fastener details.

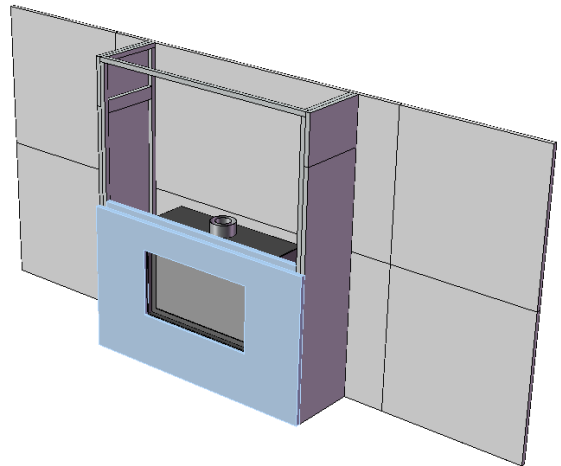

6.1 Lap joint panel

Fasten the lap joint panel by using both screws and mortar cement.

NOTE: Maintain a minimum edge distance and spacing

NOTE: FIREPLACE OPENING:

Maintain a minimum of 5 mm clearance all around to allow expansion of the board

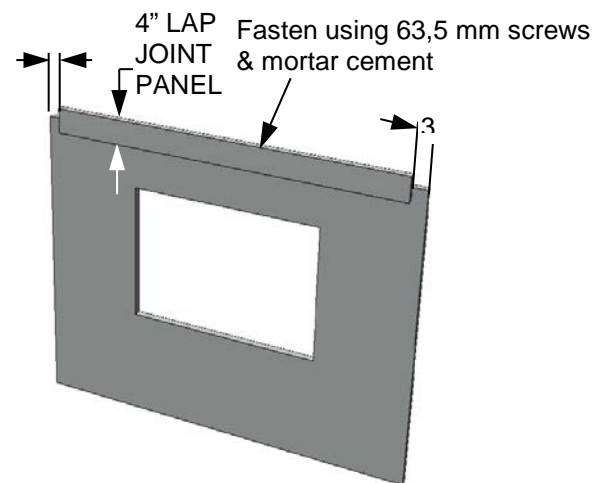

6.2 Fastening the 2 front bottom panels

Locate the 2 Skamotec 225 boards against the blocking and the side panels. Use both screws and mortar cement to fasten the boards.

NOTE: Maintain a minimum edge distance and spacing

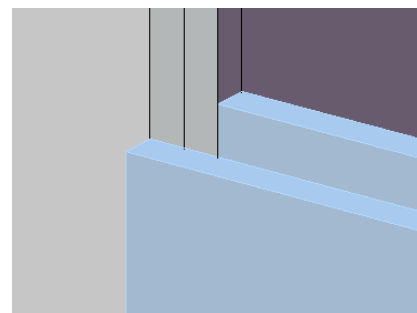

7. Installing front top panel

Fasten the Skamotec 225 board at the bottom and top against the blocking and side panels using both screws and mortar cement.

NOTE: Maintain a minimum edge distance and spacing

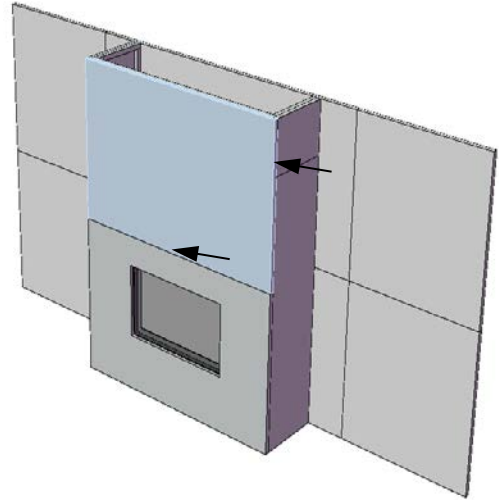

Please look at page 8 and 9 for further fastener details.

8. Complete installation

Drywall filler can be used to create a spotless finish to the surface of the fireplace

NOTE: Moisten the Skamotec 225 boards with water before applying drywall filler.

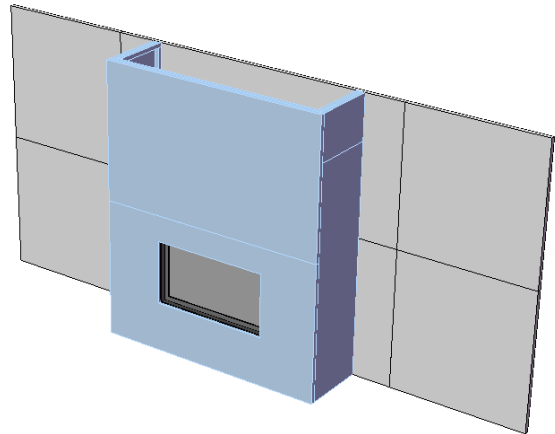

BLOCKING

Corner detail

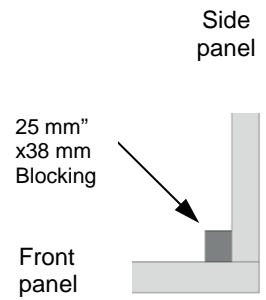

Floor detail

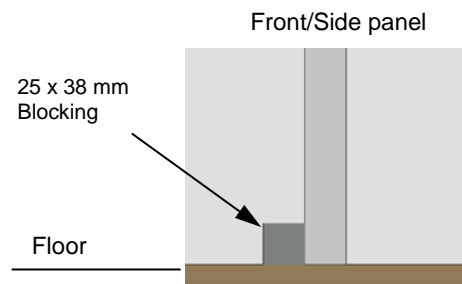

Wall detail

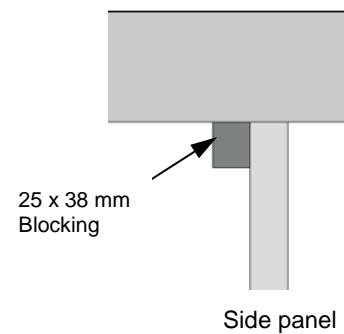

Blocking detail (plan view)

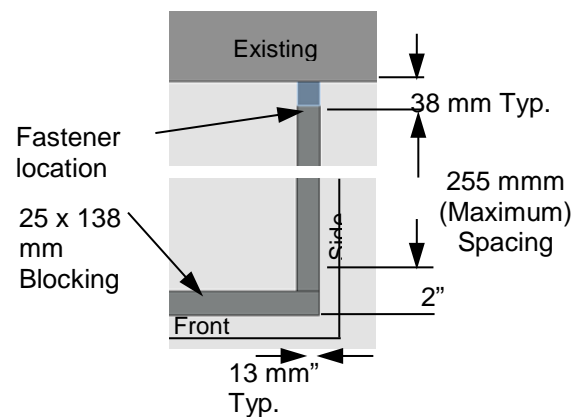

Lap joint detail

Section view

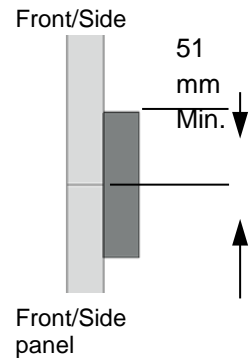

Fastener detail

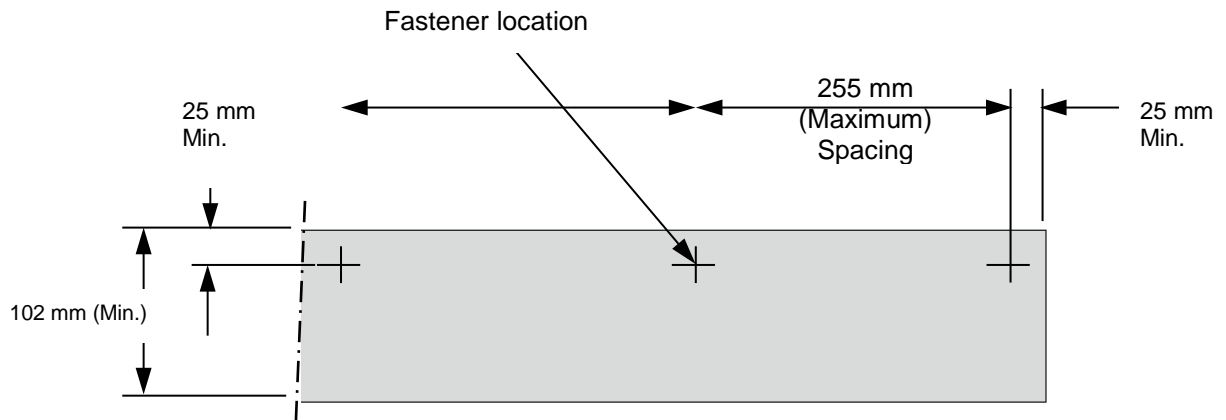

Preassembling side panels

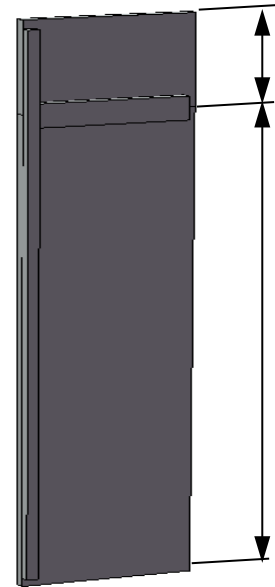

Lap joint

