



AGA 60 Electric

User Guide & Installation Instructions

CAUTION: THIS UNIT IS HEAVY, PROPER EQUIPMENT AND ADEQUATE MANPOWER MUST BE USED IN MOVING THE RANGE TO AVOID DAMAGE TO THE UNIT OR THE FLOOR.

REMEMBER, when replacing a part on this appliance, use only spare parts that you can be assured conform to the safety and performance specification that we require.

DO NOT use reconditioned or copy parts that have not been clearly authorised by AGA.

**PLEASE READ THESE INSTRUCTIONS BEFORE USING THIS APPLIANCE
AND KEEP IN A SAFE PLACE FOR FUTURE REFERENCE.**

Make a note of your AGA appliance Serial Number when it is being installed.

The serial number can be found behind the plinth cover.

My AGA Details:

Serial No:

AGA Service No:

Date of Installation:

Contents

1. Health and Safety	1	8. Installation instructions	16
2. Introduction	2	9. Installation introduction	17
3. Overview	3	10. Removal from pallet and appliance installation	18
Control panel	4	11. Specifications	20
Cooker hoods and oven venting	4	12. Electrical connection	24
General advice	5	13. Control knob and handrail connection	25
Using the zones of the AGA 60	5	14. Circuit diagram	26
Hotplate control	5	15. Checklist	27
The boiling plate setting	5		
The simmering plate setting	5		
The resting plates	6		
The ovens	6		
4. AGA accessories	7		
Roasting oven setting	9		
Baking oven setting	9		
Simmering oven	10		
5. Fitting and Removing the oven shelves	11		
6. Cleaning & Caring for your Cooker	13		
7. Servicing	15		

1. Health and Safety

⚠ CHILDREN SHOULD BE KEPT AWAY FROM THE APPLIANCE AS SOME SURFACES CAN BECOME HOT TO THE TOUCH.

The appliance may contain some of the materials that are indicated below. It is the Users/Installers responsibility to ensure that the necessary personal protective clothing is worn when handling where applicable, the pertinent parts that contain any of the listed materials that could be interpreted as being injurious to health and safety, see below for information.

Glues and Sealants

Exercise caution - if there are still in liquid form use face mask and disposable gloves.

Glass Yarn, Mineral Wool, Insulation Pads, Ceramic Fibre

May be harmful if inhaled. May be irritating to skin, eyes, nose and throat. When handling avoid contact with skin or eyes. Use disposable gloves, face-masks and eye protection. After handling wash hands and other exposed parts. When disposing of the product, reduce dust with water spray, ensure that parts are securely wrapped.

General

⚠ NEVER place anything aluminium between the saucepan base and the ceramic surface (i.e. cooking mats, aluminum foil, etc).

⚠ IMPORTANT: Oil is a fire risk; do not leave pans containing oil unattended.

- In the event of a fire cover with a lid and switch OFF the electricity.
- Smother the flames on the hob rather than attempting to remove the pan to the outside.
- Burns and injuries are caused almost invariably by picking up the burning pan to carry outside.

Deep Fat Frying

- Use a deep pan, large enough to completely cover the appropriate heating area.

⚠ NEVER fill the pan more than one-third fill of fat or oil.

⚠ NEVER leave oil or fat unattended during the heating or cooking period.

The appliance can be used by children aged from 8 years and above and persons with reduced physical, sensory or mental capabilities or lack of experience and knowledge if they have been given supervision or instruction concerning use of the appliance in a safe way and understand the hazards involved. Children less than 8 years of age shall be kept away unless continuously supervised. Cleaning and user maintenance shall not be made by children without supervision.

⚠ The appliance and its accessible parts become hot during use and will retain heat even after you have stopped cooking. Care should be taken to avoid touching heating elements.

⚠ DO NOT modify this appliance. This appliance is not intended to be operated by means of external timer or separated remote-control system.

⚠ Take care NOT to place metallic objects such as knives, forks, spoons and lids on the hob surface since they can get hot.

⚠ CAUTION: The cooking process has to be supervised. A short term cooking process has to be supervised continuously.

⚠ WARNING: Unattended cooking on a hob with fat or oil can be dangerous and may result in fire. NEVER try to extinguish a fire with water, but switch off the appliance and then cover flame e.g. with a lid or fire blanket.

⚠ WARNING: Danger of fire: Do not store items on the cooking surfaces.

⚠ WARNING: Accessible parts may become hot during use. Young children should be kept away.

⚠ WARNING: If the hob surface is cracked, switch off the appliance to avoid the possibility of electric shock.

⚠ Any spillage should be removed from the lid before opening.

⚠ Hob surface should be allowed to cool before closing the lid.

2. Introduction

As responsible manufacturers we take care to make sure that our products are designed and constructed to meet the required safety standards when properly installed and used.

Any alteration that is not approved by AGA could invalidate the approval of the appliance, operation of the warranty and could affect your statutory rights.

In the interests of safety and effective use, please read the following before using your new AGA appliance.

Installation must be to local and national wiring regulations and carried out by a qualified engineer.

A little smoke and some odour may be emitted when first switched on. This is normal and harmless (from oven lagging and starch binder on the element insulation) and will cease after a short period of use.

Consumer Law (Australia Only)

Our goods come with guarantees that cannot be excluded under the Australian Consumer Law. You are entitled to a replacement or refund for a major failure and compensation for any other reasonably foreseeable loss or damage. You are also entitled to have the goods repaired or replaced if the goods fail to be of acceptable quality and the failure does not amount to a major failure.

3. Overview

Fig. 3.1



DESN 517541

Cooker overview Fig. 3.1

- A. Simmering Plate and Boiling Plate
- B. Top Plate and Resting Area
- C. Top Oven (Roasting Oven and Baking Oven setting)
- D. Simmering oven

Control panel

When switching on the AGA cooker for the first few times, there are two things you may notice, neither of which should cause concern.

The AGA cooker will emit an odour for a short while, this is simply due to the protective oil we put on the hotplate and ovens burning off. Due to the newness in the first couple of hours, it is advisable to open the kitchen window while this takes place.

Condensation may occur on the top and front plate whilst the AGA cooker is heating up, caused by the insulation lagging and starch binder on the element insulation drying out. The condensation should be wiped away as soon as possible to prevent staining the enamel.

Your AGA 60 has the external appearance of a classic AGA heat storage enamelled cast iron cooker. However, it's flexibility is almost unbounded because in place of a single heat source each cooking zone has its own electrically heated cast iron element (s). The separation of cooking zones, allows a choice of control. You are able to select only the zones that you want, or need, to use.

Cooker hoods and oven venting

It is recommended that this AGA is fitted with a cooker hood above it. The AGA venting system is located on top of the AGA and is designed for venting the moisture from the ovens. The cooker hood should be positioned not less than the minimum height as recommended by the manufacturer, from the top of the AGA.















The AGA 60 ovens are manufactured from cast iron, over a period of time they will become individually seasoned.

However, the ovens will rust if high moisture content foods are not covered (especially in the simmering oven) or spillages are not cleaned up.

It is also not advisable to leave a full or partially filled saucepan/utensils with high moisture content food in the ovens when they are not in use.

To season the ovens a light vegetable oil is ideal (corn oil is best), spray oil is recommended. Any stubborn stains can be removed with the wire brush supplied.

Cleaning details can be found on **"Cleaning & Caring for your Cooker"** on page 13.

Hobs	
OFF	
Boiling Setting	
Simmering Setting	
Oven	
OFF	
Top Oven Baking Setting ON Simmering Oven OFF	 
Top Oven Baking Setting ON Simmering Oven ON	 
Top Oven - OFF Simmering Oven ON	 
Top Oven Roasting Setting ON Simmering Oven ON	 
Top Oven Roasting Setting ON Simmering Oven OFF	 

General advice

Food should not be placed into any oven until it is up to normal operating heat.

The oven doors should not be left open for long periods of time during cooking and heating up.

Store the cold plain shelf outside the cooker. Use it cold in the roasting oven to deflect heat from the top of the oven, creating a more moderate oven temperature underneath. It can also be used as a baking sheet.

Warm up times

As the AGA works on the principle of storing heat, time is required to gather that heat from the electric elements to saturate the castings. **We recommend to allow an hour heat up time.** The optional programmer is a great asset as it can be set to get the top oven to its working heat, ready for you to cook when you walk through the door.

The principle of heat storage means that the ovens and hotplate are at a pre-set heat, the cooking areas are named after their function rather than temperatures.

Using the zones of the AGA 60

The different zones of the AGA 60 cooker are described individually, in the following pages.

The traditional AGA heat storage cooker is famous for the gentle warmth it emits, with the AGA 60 you will get warmth only when the cooker is on or warmth to a lesser degree when only parts of it are on.

The hotplate

The cast iron hotplate is operated manually and is machined flat to give the best all-over contact with the AGA saucepans, grill pan, frying pan and kettle.

The boiling plate setting is the hottest with the simmering plate setting being cooler. It has electric elements embedded into the cast iron which heat up in approximately 11 and 8 minutes respectively. The hotplate can be used completely independently from the ovens.

The whole hotplate area can be used for cooking and several pans can be accommodated on the plate at any one time. The hotplate is set very slightly above the top plate to minimise scratching as the pans are pulled to one side to simmer.

The chrome insulated cover is brought down over the hotplate when it is heating up or not in use. When the hotplate is 'ON' the insulated cover will be warm. We strongly advise not to put anything such as kettles, saucepans or baking tins directly onto the insulated cover because it will show any scratches - invest in a chef's pad to protect the surface if the cover is to be used as a resting place!

Keep the hotplate clear of any burnt on food or crumbs by brushing with the wire brush, supplied with your AGA. Cleaning details can be found on **"Cleaning & Caring for your Cooker"** on page 13.

Hotplate control

To operate the boiling plate setting turn the control knob to the ● position and similarly to the ☐ for the simmer plate setting.

The boiling plate setting

The hottest setting, the boiling plate setting is used for boiling, grilling, stir-frying, making toast - indeed anything that requires a high heat. Green vegetables keep their colour when boiled quickly here, or use a steamer over the saucepans to cook more than one vegetable at once.

When stir-frying or cooking anything that is inclined to splash we would recommend using an AGA Splash Shield which will protect the insulated cover from splatter, making cleaning a doddle! Just wash the Splash Shield in hot soapy water or place in a dishwasher between two dinner plates.

Please be advised the boiling plate setting is too hot to cook food directly on it.

The simmering plate setting

The simmering plate setting is the cooler of the two settings and so is used for recipes that require a lower heat such as, making sauces, scrambling eggs, heating milk, slow frying, simmering soups and root vegetables. In addition, it can be used to cook on directly as a form of griddle - invaluable for toasted sandwiches, quesadillas, drop scones, searing scallops and even a non-fat fried egg! Slow cooked toast can be made on the simmering plate setting, no need to use the AGA toaster here.

Fig. 3.2

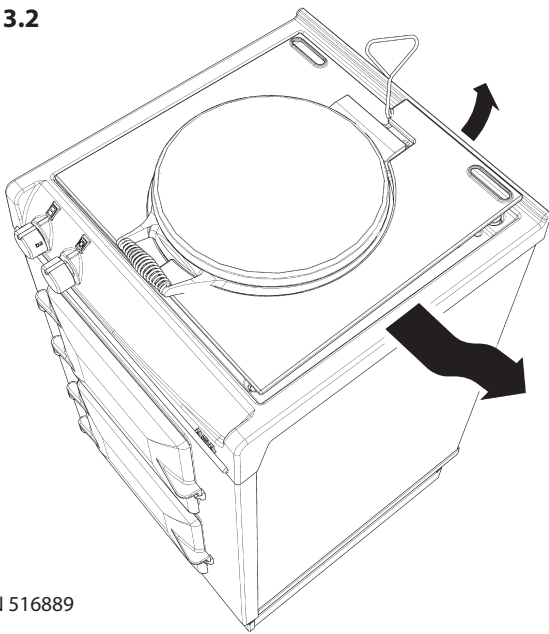

DESN 516889

The resting plates

The resting plates are useful when you wish to move a pan off boil or to a lower temperature.

Take care when removing and replacing the cast iron resting plates, as they are heavy. Ensure they are cold before removing.

Removing resting plates

Insert lifting tool in recess at rear of resting plate. Lift up at rear, the slide out carefully from the side, **Fig. 3.2**.

Replacement of resting plates

Replace resting plates carefully, as shown in **Fig. 3.3**.

The ovens

Your AGA 60 has two ovens which are pre-set at a different heat, just like the traditional AGA heat storage cooker. The top oven has two temperature settings one for the roasting and one for baking.

Top Oven

- The roasting oven setting for high temperature cooking
- The baking oven setting for moderate temperature cooking
- The simmering oven for long, slow cooking.

⚠ DO NOT OPERATE THIS APPLIANCE WITH THE DOORS OPEN, SINCE THIS CAN CAUSE A LOCK-OUT.

Each oven has the same capacity, (able to fit a 13kg (28lb) turkey) and the traditional AGA heat-storage cooker techniques can be used, such as stacking saucepans in the simmering oven. This enables the steaming of root vegetables, rice, steamed pudding, casserole, poaching fruit all in the same oven leaving the hotplate free.

You can have one or two ovens on at their pre-set heat.

The ovens are made from cast iron, which cooks by a radiant heat and this is the secret of the cooking excellence for which the AGA cooker is renowned. An indirect radiant heat does not dry food out, so it retains its natural moisture and flavour.

Fig. 3.3

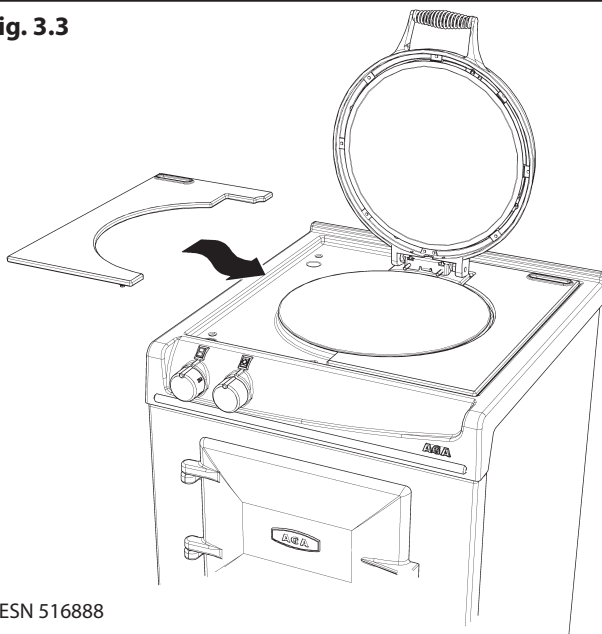

DESN 516888

4. AGA accessories

To get the very best performance from your range we recommend AGA saucepans with the thick tri-core bases and stacking lids so that the maximum use of oven space is made and an AGA kettle for boiling water. AGA Accessories can be viewed at your AGA Specialist or online at www.agacookshop.co.uk

Getting to know your AGA

If you have not already seen a demonstration, ask your AGA Specialist for details. A demonstration will show you how to get the best from your new AGA and will give you hints and tips. You will also see a selection of AGA utensils and accessories being used.

Large Size Roasting Tin with Grill Rack (Fig. 4.1)

This is designed to slide onto the oven runners without the need for it to sit on an oven grid shelf. The roasting tin can be used with the grill rack, in its high position, for grilling at the top of the roasting oven. It can be used for roasting meat, or poultry with or without the grill rack. Large quantities of roast potatoes can be cooked in this tin. The roasting tin can also be employed for making large traybakes or cakes. The grill rack is useful on its own as a cake cooling rack. Can be used in any oven but not recommended for hotplate use.

Half Size Roasting Tin and Grill Rack (Fig. 4.2)

This tin can be slid onto the oven runners width-ways or can sit on an oven grid shelf. The half size roasting tin can be used with the grill rack, in its high position, for grilling at the top of the roasting oven. It can be used for roasting smaller joints of meat, or poultry with or without the grill rack. Roast potatoes can be cooked in this tin. The roasting tin can also be employed for making traybakes or cakes. The grill rack is useful on its own as a cake cooling rack. Can be used in any oven but not recommended for hotplate use.

2 Floor Grid (Fig. 4.3)

This grid is used on the floor of the ovens, in particular the roasting and simmering ovens to protect food needing over 30 minutes cooking from the intensity of the heat from the base element.

2 Oven Grid Shelves (Fig. 4.4)

These are for inserting in each oven to provide a surface for dishes and tins which do not fit direct onto the oven runners. They can be used in any oven, as required.

Fig. 4.1



Fig. 4.2



Fig. 4.3

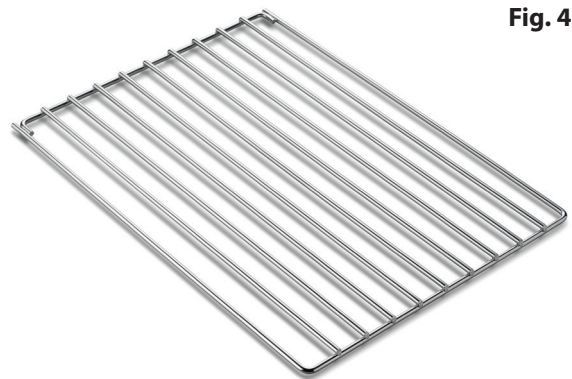

Fig. 4.4

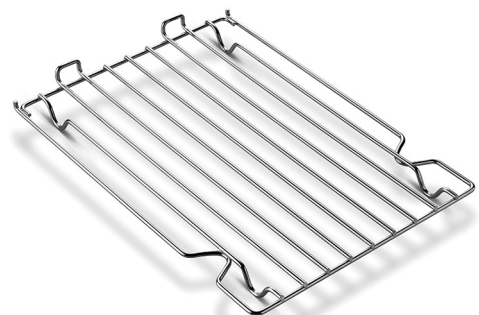

Fig. 4.5



1 Cold Plain Shelf (Fig. 4.5)

This has two uses one as large baking sheet for scones, biscuits, pastry items and meringues and the other use as a heat deflector to cut off the top heat if food is overbrowning before it is cooked through.

⚠ DO NOT STORE IN THE OVENS WHEN NOT IN USE.

Toaster (Fig. 4.6)

This is for toasting bread on the boiling plate. AGA toast is renowned for its excellence, crisp on the outside and soft in the centre. Take thick slices of bread and place in the AGA toaster - if the bread is very moist or very fresh, heat the toaster beforehand to prevent sticking - lift the boiling plate insulated cover and place the toaster direct onto the plate with the handle at an angle from the handle of the cover.

Close the cover and wait for the bread to toast one side - this will take 1-2 minutes dependent upon the variety of bread - open the cover and turn the toaster over and repeat the process to toast the other side. The toaster can also be used for heating pitta bread, toasting teacakes and as a cake cooling rack.

Wire Brush (Fig. 4.7)

This is for cleaning the raw cast iron surfaces, keeping them clear of crumbs and burnt on debris - which would otherwise affect the boiling performance of pans and the kettle. Use on the hotplates and the ovens. Take care not to touch the enamel surfaces as the wire brush will scratch the finish.

Resting plate lifting tool (Fig. 4.8)

To aid removal of the cast iron resting plates for cleaning.

Getting to know your AGA

If you have not already seen a demonstration, ask your AGA Specialist for details. A demonstration will show you how to get the best from your new AGA and will give you hints and tips. You will also see a selection of AGA utensils and accessories being used.

Fig. 4.6



Fig. 4.7



Fig. 4.8

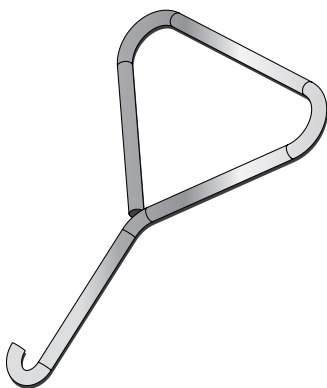

Roasting oven setting



The roasting oven setting is indirectly heated by two elements, one in the base of the oven and the other in the roof. These elements heat the air and the cast iron within to provide cooking results consistent with the traditional AGA heat-storage cooker, with the flexibility of

being able to turn the off when not in use.

The roasting oven setting can be used for 'grilling' at the top and 'shallow frying' on the oven floor.

When cooking on the base of the roasting oven, place the floor grid on the base before putting the food into the oven. This lifts the food away from the base element to ensure best cooking results are achieved.

The roasting oven setting is zoned in heat, meaning it is slightly hotter towards the top than the centre and the oven grid shelf set on the oven floor is slightly less hot than the centre.

The base of the oven can be used as another cooking surface, indeed it is often called a hidden hotplate use the floor grid for protection so food does not overbrown.

The beauty of the roasting oven setting is that any fat is burnt off when the oven is at full heat, just brush out occasionally to remove the carbon deposits.

The roasting oven setting is excellent for bread and pastries. Quiches in ceramic or pies in Pyrex dishes need not be baked blind as when they are in placed on the floor grid on the base of the oven the pastry cooks from underneath and the filling will set and brown from the all-round heat. As you are aware metal flat tins conduct heat quicker than ceramic may need less cooking time.

The specially designed roasting tins and bakeware slide directly onto the runners, so almost every available square centimetre of space can be used. Food can be protected by the use of the cold plain shelf or shielded by means of the large roasting tin which means you can cook food that requires different temperatures at the same time. If food is browning too quickly and you do not want to move it to another oven just slide the cold plain shelf over the food to reduce the top heat.

Baking oven setting

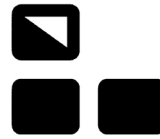

The oven is indirectly heated by two elements, one in the base of the oven and the other in the roof. These elements heat the air and the cast iron within to provide cooking results consistent with traditional AGA heat storage cookers, with the flexibility of being able to turn it off when not in use.

This setting is a moderate heat, so is ideal for cakes, biscuits, also anything that requires medium heat cooking such as fish pie, lasagne, soufflés, crumble and roulades. Meat and poultry can be cooked here indeed most things that can be cooked on the roasting oven setting can be cooked on the baking oven setting but for a longer time.

For the best results when cooking cakes do allow at least the one hour heat up time. Cook cakes together on one shelf. If two shelves are used interchange the food to achieve even colouration, as you would with any oven which is zoned heat.

As with the roasting oven setting, the specially designed roasting tins and bakeware slide directly onto the runners, so almost every available square centimetre of space can be used. Food can be protected by the use of the cold plain shelf or shielded by means of the large roasting tin, which means that you can cook food that requires different temperatures at the same time. If food is browning too quickly and you do not want to move it to another oven just slide the cold plain shelf over the food to reduce the heat.

NOTE: When baking it is always best to start from cold, otherwise if baking after using the roasting setting the oven will take a considerable amount of time to cool.

NOTE: Always remove the cold plain shelf and roasting tins on completion of cooking, if left in the oven it will affect the oven temperature.

Simmering oven



The simmering oven is indirectly heated by one element in the base of the oven.

This element heats the air and the cast iron within it to provide cooking results consistent with the traditional simmering oven of the traditional AGA heat-storage cooker, with the flexibility of being able

to turn it off when not required.

The floor grid is used here to protect items placed on the base of the oven such as vegetables for steaming, keeping sauces warm or casseroles cooked for a long time. Always ensure this is in place, before putting food into the oven.

The simmering oven can be described as a continuation oven, it continues to cook food that has been brought up to heat elsewhere on the cooker with the exception of meringues which are dried out rather than 'cooked'.

User Guidance

- Allow the oven to heat fully, the longer the oven is on the better, we recommend one hour.
- To get the very best performance, we recommend to use AGA cookware with thick bases and stacking lids.
- **DO NOT** place dishes directly on to the oven base. Always place onto either a shelf or the floor grid.
- Joints of meat and poultry should be brought up to heat ideally on the roasting oven setting for 30-45 minutes, then transferred to the simmering oven.
- This method is unsuitable for stuffed meat and stuffed poultry).
- Make sure that pork and poultry reach an internal temperature of at least 75°C.
- Always bring soups, casseroles and liquids to the boil before putting in the simmering oven.
- Always thaw frozen food completely before cooking.
- Root vegetables will cook better if cut into small pieces.
- Adjust seasoning and thickenings at the end of the cooking time.
- Many dried pulses and beans for example, dried red kidney beans must be boiled for a minimum of 10 minutes, after soaking, and before inclusion in any dish.

5. Fitting and Removing the oven shelves

Fitting the shelves for cast iron, roasting, baking and simmering ovens

Fig. 5.1

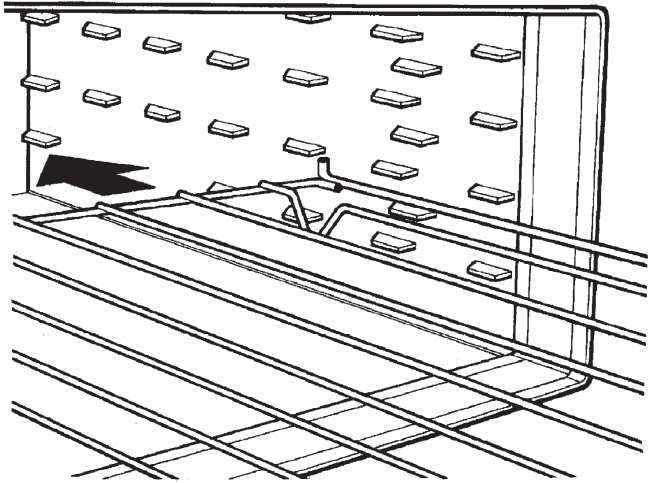

DESN 512403

Fig. 5.2

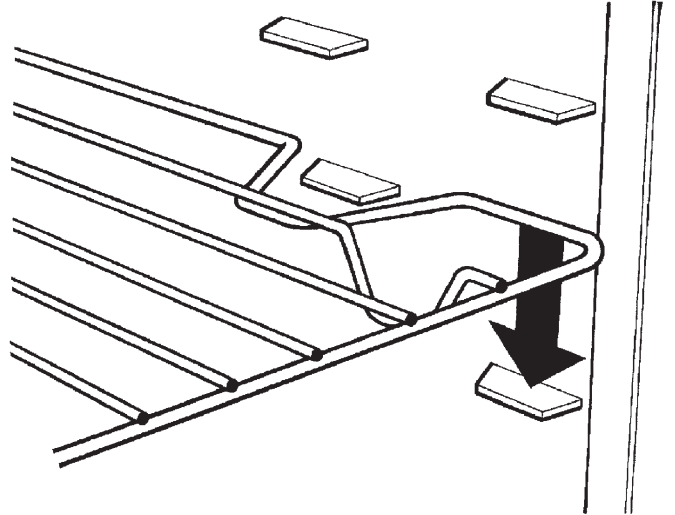

DESN 512404

Removing the shelves for cast iron, roasting, baking and simmering ovens

Fig. 5.3

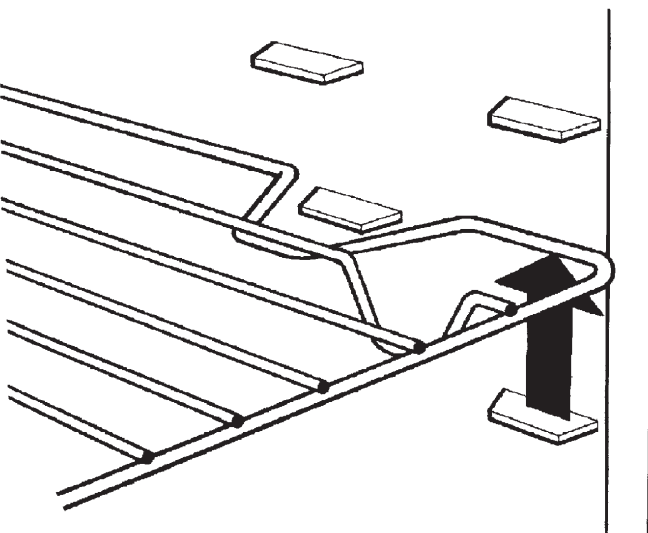

DESN 512405

Fig. 5.4

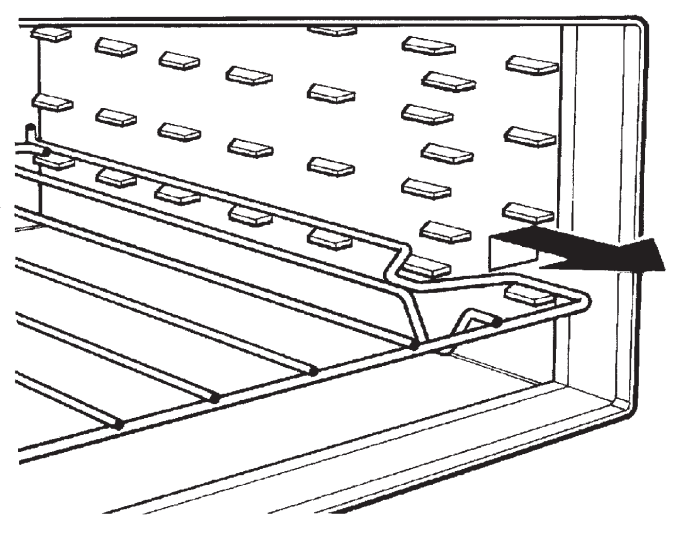

DESN 512406

Cooking table - Radiant Ovens

Roasting oven setting	Oven temperature = HIGH
Grilling	Top - grilling
Scones	2nd runner - scones, small pastries, grilling
Pastries	3rd runner - bread rolls , Yorkshire puddings
Bread	4th runner - roasts, poultry
Yorkshire puddings	Oven grid shelf on base of oven - bread loaves, pies, roast vegetables
Roasts	Floor grid on base of oven - quiches, pies
Shallow frying	
Baking oven setting	Oven temperature = MODERATE
Cakes	Towards top - whisked sponges, some biscuits, small cakes
Biscuits	Middle - fish, soufflés, shepherd's and Cottage pie, lasagne
Fish Shepherds pie, Cottage pie Lasagne Soufflés Shortbread	Oven grid shelf on base of oven - Victoria sandwiches, shortbread, traybakes and cheesecake
Simmering oven	Oven temperature = LOW
Casseroles Milk puddings Stock Meringues Rich fruit cake	For casseroles, stock, milk puddings and similar dishes bring to heat on the hotplate or induction hob, then transfer to the simmering oven (one exception is meringues). To dry out meringues place on baking sheet on floor grid in Simmering oven. Rich fruit cakes can be cooked here for a, long time on the oven grid shelf placed on the base of the oven.

Hotplate & Oven Seasoning

The hotplates and ovens within your AGA Rangemaster appliance are made from cast iron and are very durable; however, cast iron will naturally oxidise in most environments.

All surfaces of the ovens and hotplate(s) must be fully dried and evenly seasoned.

All ovens and hotplates should be regularly seasoned with a suitable cooking oil, (see note on smoke points). This is done by either spraying or rubbing oil onto all exposed uncoated cast iron surfaces in the ovens and on the hotplates, and then heating them to season the oil into the castings surface. Over time, this will create a protective layer that will prevent moisture from causing oxidation.

This process should be repeated once a week for 6 weeks when your appliance is first received.

If at any point your appliance is not due to be used for an extended period, the seasoning process should be followed.





Recommended oils for seasoning cast iron.

Most cooking oils can be used for seasoning cast iron. Consideration should be taken to the smoke point temperature. The adjacent table list suitable oils in order of their smoke point.

The values in this table represent the typical smoke point for commercially available edible oils. Smoke points may vary within a source oil due to such factors as processing techniques and / or seasonal variations.

TYPE of OIL	Smoke Point °C
Avocado Oil (Virgin)	271.1
Safflower Oil	260.0
Rice Bran Oil	232.2
Soybean Oil	232.2
Peanut Oil	232.2
Corn Oil	232.2
Sunflower Oil	226.7
Canola Oil	218.3
Grapeseed Oil	215.6
Vegetable Oil	204.4
Extra-Virgin Olive Oil	190.6
Vegetable Shortening	182.2
Coconut Oil	176.7

6. Cleaning & Caring for your Cooker

-  Always SWITCH OFF at mains before cleaning.
-  DO NOT use a steam cleaner to clean this cooker.
-  When cleaning use as little water as possible.
-  DO NOT use abrasive pads, oven cleaner or cleaners containing citric acid on enamelled surfaces.

Enamelled Top and Front Plate

The easiest way to clean the AGA top plate and front plate is to mop up spills as they happen. VEA approved AGA Enamel Cleaner can be purchased at www.agacookshop.co.uk.

Baked on food is more difficult to clean but can usually be removed with proprietary vitreous enamel cleaners or mild cream cleaners using a cloth, or if necessary, a nylon scouring pad.

If milk or fruit juice, or anything containing acid is spilt on the enamel, wipe off immediately.

Clean off any condensation streaks on the front plate around the oven doors or the vitreous enamel maybe permanently discoloured.

All that is usually needed to keep the vitreous enamelled surfaces of your cooker bright and clean is a daily rub over with a damp, soapy cloth followed immediately with a clean, dry cloth to avoid streaks.

Remember the top plate will scratch if pans or utensils are dragged across them.

The Ovens

The fan oven is fitted with a back panel which is of self cleaning enamel and should not be scoured.

All of the remaining surfaces of both ovens are vitreous enamelled and can be cleaned with proprietary vitreous enamel cleaners approved by the Vitreous Enamel Association.

The shelves can be removed and if necessary the shelf supports may also be removed by taking out the screws.

These items may be washed in the sink with normal oven cleaners, you may use a fine wool soap pad for removing stubborn stains from the oven bases and shelf supports.

 **NOTE: Take care not to damage the thermostat phials in the ovens when cleaning.**

Heat Clean Enamel

Fan oven - back panel only

This special enamel has a continuous cleaning action, which works best if a pattern of low and high temperature cooking is followed. By using low temperature roasting, excessive fat splashes can be avoided. Should any excessive staining occur, immediately clean the area with hot water containing detergent, and a nylon washing-up brush. Resistant stains require the oven to be run at 210°C for 2 hours.

DO NOT use any cleaning materials which may clog the pores of the special coating e.g. pastes and powders, soap filled pads, spray cleaners, brush-on oven cleaners, caustic solutions, metal scrapers/knives, and prevent the cleaning action.

Door Liners

May be cleaned with a cream cleaner or soap impregnated pad.

Lift off the oven doors to allow them to cool a little before cleaning. **DO NOT**, however, immerse the doors in water as they are packed with insulating material which will be damaged by excessive moisture.

Controls

The enamelled surface under the knobs can be treated as in the Section 'Door Liners'. Avoid the use of excessive water.

DO NOT use oven cleaners, scouring pads and abrasive powder for cleaning the plastic knobs. A wipe with a damp cloth should be sufficient.

TIP: Clean your Module regularly, Preferably every time you use it.

IMPORTANT: AGA recommend Vitreous Enamel Association approved cleaners for cleaning the vitreous enamelled surfaces of this product.

Accessories

 **Oven furniture such as Roasting Tins, Solid Plain Shelves, Grid Shelves, and Grill Racks should be cleaned in hot soapy water, soak if necessary, a nylon scouring pad can be used.**

7. Servicing

- To keep your Aga appliance running efficiently we recommend that it is regularly serviced by an Approved Aga engineer. Approved Aga engineers have been factory trained and always use genuine Aga spares
- In the event of requiring maintenance, please call AGA Service or your authorised distributor.
- Your appliance **MUST** only be serviced by a qualified engineer from AGA or an authorised distributor.
- **DO NOT** alter or modify the appliance.

 **A hot appliance cannot be serviced.**

Service intervals to maintain the appliance warranty are as follows:

- An interim service is due at 2 ½ years (30 months) to check and change consumable items, and to undertake a safety check.
- A full service is due at the end of year 5 (60 months). The appliance does not cover Commercial use (see separate warranty book provided for further details).

Spare Parts

To maintain optimum and safe performance, we recommend that only genuine AGA spare parts are used. These are available from most major spares stockists, including ourselves.

8. Installation instructions

WARNING!

Please read the Warning, Cautionary notes at the start of this section. If the information contained within these instructions is not followed, property damage or personal injury may occur.

DO NOT store or use gasoline or other flammable vapors and liquids in the vicinity of this or any other appliance.

Installation and service must be performed by a qualified installer or service agency.

WARNING! This appliance must be installed with an appropriate device that will allow permanent disconnection of the Live and Neutral conductors. During Installation or disconnection prior to any electrical work, the appliance must be permanently disconnected from the Supply (Live) and Neutral Conductors.

CAUTION: THIS UNIT IS HEAVY, PROPER EQUIPMENT AND ADEQUATE MANPOWER MUST BE USED IN MOVING THE RANGE TO AVOID DAMAGE TO THE UNIT OR THE FLOOR.

REMEMBER, when replacing a part on this appliance, use only spare parts that you can be assured conform to the safety and performance specification that we require.

DO NOT use reconditioned or copy parts that have not been clearly authorised by AGA.

**PLEASE READ THESE INSTRUCTIONS BEFORE USING THIS APPLIANCE
AND KEEP IN A SAFE PLACE FOR FUTURE REFERENCE.**

9. Installation introduction

Consumer protection

As a responsible manufacturer, we take care to make sure that our products are designed and constructed to meet the required safety standards when properly installed and used.

⚠ WARNING - ELECTRIC SHOCK HAZARD

It is the customers responsibility to contact a qualified electrical installer to make sure the electrical installation is adequate and in conformance with the regulations.

Take special care when cutting holes in walls or floor. Electrical wires may be behind the wall or floor covering and could cause an electrical shock if you touch them.

Locate any electrical circuits that could be affected by the installation of this product and disconnect power circuit.

⚠ WARNING: THIS APPLIANCE MUST BE EARTHED.

DO NOT use an extension lead with this appliance.

The appliance is designed for the voltage stated on the data plate.

Recommended but not mandatory to fit an individual Residual Current Device (RCD) to the cooker supply circuit.

Hand this Manual to the User for retention and instruct in the safe operation of the appliance.

10. Removal from pallet and appliance installation

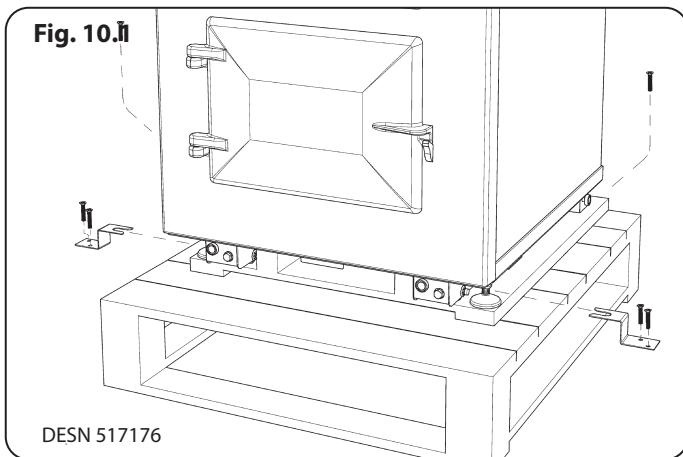

1. Removing of transit brackets - Unscrew 4 screws and remove brackets, from front and two screws from rear (**Fig. 10.1**).
2. **NOTE:** Care must be taken not to trap mains cable. Appliance to be removed from rear of pallet only. Recess provided for suitable sack truck. Appliance to be secured to sack truck with suitable straps (shaded area) (**Fig. 10.2**).
3. Once appliance is in position in kitchen, remove sack truck and straps. The front stability feet can be raised with a spanner to allow appliance to be slid from transit pallet (**Fig. 10.3**).
4. Slide cooker off transit pallet. Take care not to trap mains cable (**Fig. 10.4**).

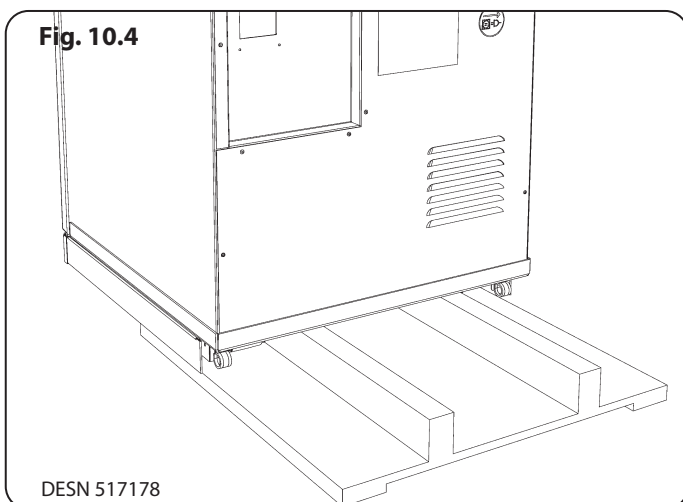
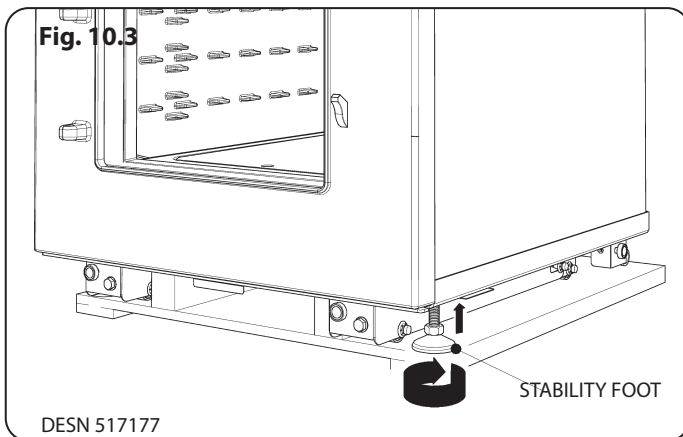
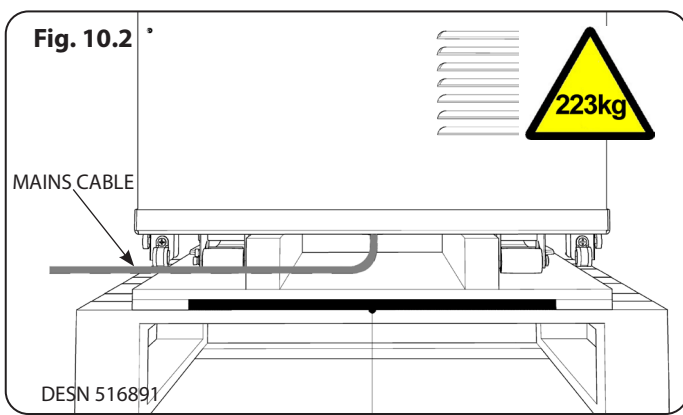

5. Appliance can now be pushed back on its wheels into desired position. **NOTE:** Care must be taken not to trap mains cable (**Fig. 10.5**).
6. **Levelling of appliance** - Use 13mm socket to adjust wheel mechanism for FINE adjustment on both sides at rear of the appliance (**Fig. 10.6**).
7. Using a 12mm open end spanner, feet can be adjusted at front to make FINE adjustments to the front of the appliance and to provide a brake for the wheels (**Fig. 10.6**).
8. Turning the bolt clockwise will lower the wheel thus increasing height of the cooker (**Fig. 10.6**).
9. Anti-clockwise lifts the wheels and lowers the cooker (**Fig. 10.6**).
10. Fit the magnetic plinth (**Fig. 10.7**)
11. **Resting Plate Adjustment** - Resting plates have adjuster screw feet for setting of height and to improve stability (**Fig. 10.8**).

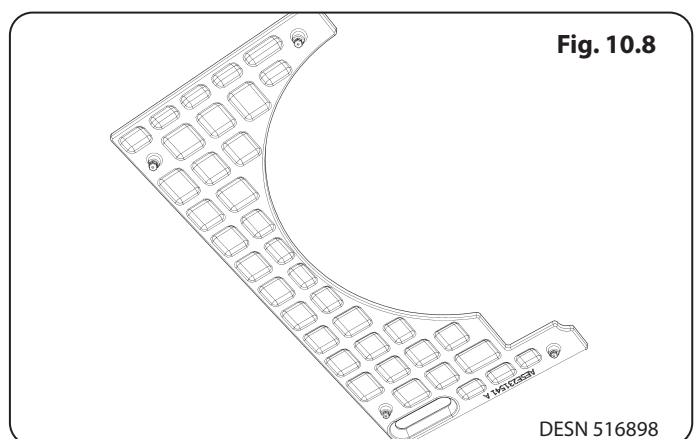
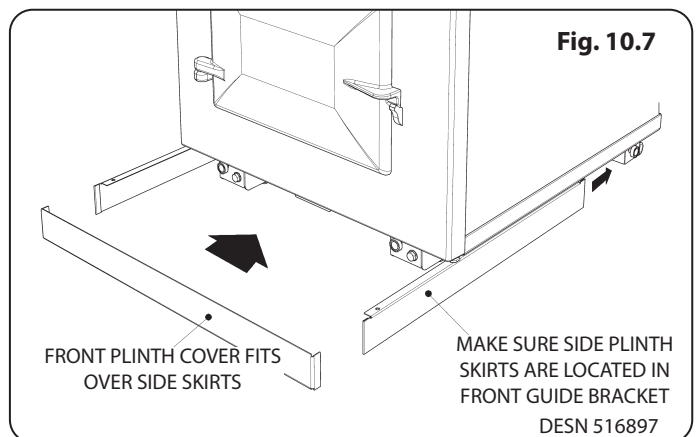
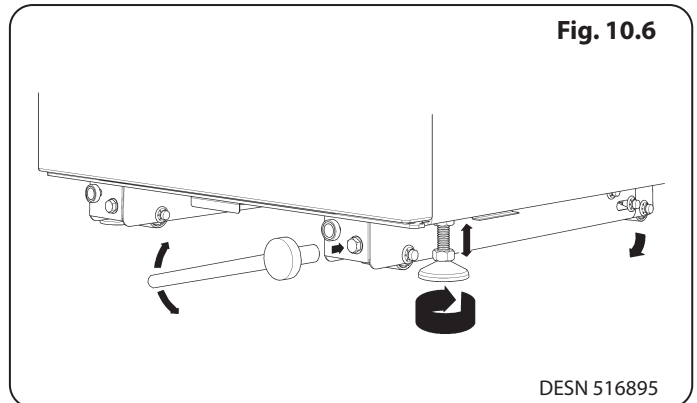
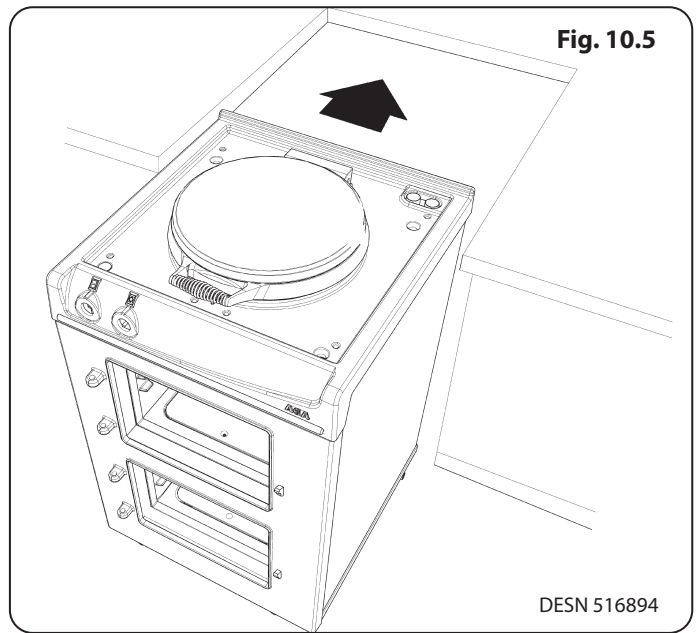

11. Specifications

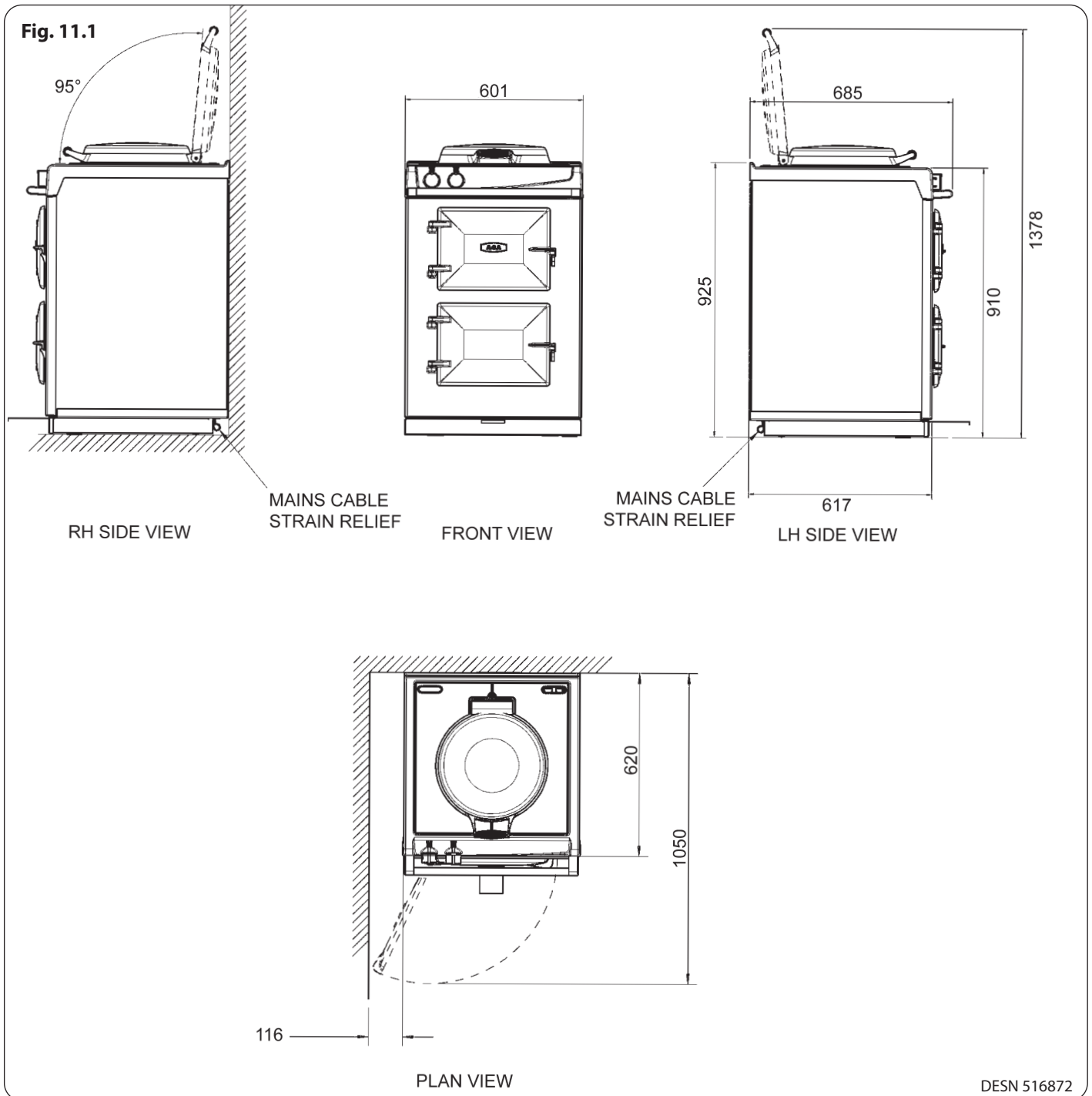

DESN 516872

Clearances for overhead cupboards - **Fig. 11.1.**

NOTE: When surveying for a appliance installation the actual clearance required for the 'body' of the appliance should be increased overall by 10 mm ($\frac{3}{8}$) beyond the figures quote above. This allows safe margin to take into account the natural dimensional variations found in major castings in particular the width across an appliance recess could be critical.

Appliance weight (Excludes packaging)

Model: AGA 60 Electric 492 lbs (223 kg)

Side Clearances

If you are installing the appliance in a new kitchen or have the opportunity to set the width between kitchen units, it is advisable to include an additional small gap each side of 3mm to assist with installation and prevent damage when moving the product.

A 6mm additional width clearance should also be provided if the appliance is to go into a brick recess, to allow for the wall being out of square.

Where it is installed against a side wall protruding in the front of the appliance a 116mm clearance is required on the left hand side for the oven door access.

Any side wall above the appliance on either side shall not be less than 60mm horizontally from the appliance (**Fig. 11.1**).

Surfaces over the top of the appliance must not be closer than 650mm.

The vent slot in the back of the top plate must not be obstructed.

Fitting into a 60cm gap

If you are restricted to a 60cm width space, the AGA 60 will fit, subject to the following guide (**Fig. 11.2**).

The appliance top plate casting width tapers outwards at its bottom edge. Consequently adjacent cupboard units should have a maximum depth of 595mm (including doors). If they are deeper, bring the appliance forward.

The thickness of adjacent worktops should not exceed 45mm.

Appliance Base or Hearth

It is essential that the base or hearth on which the appliance stands should be level and be capable of supporting the total weight of the appliance.

The front plinth cover is removable and must not be obstructed by flooring or tiles. If necessary the appliance must be raised by the thickness of the tiles to ensure the plinth can be removed, and the appliance can be rolled out for service.

Tiling

When the appliance is to stand in a recess or against a wall which is to be tiled, in no circumstances should the tiles overlap the appliance top plate, access to remove the top plate must be allowed for servicing at a later date.

Option Pre-heat Timer Kit (AE4M231659)

If the optional pre-heat timer kit is fitted allowances must be made for timer location and the cable between the timer and appliance. Timer cable is 4 metres.

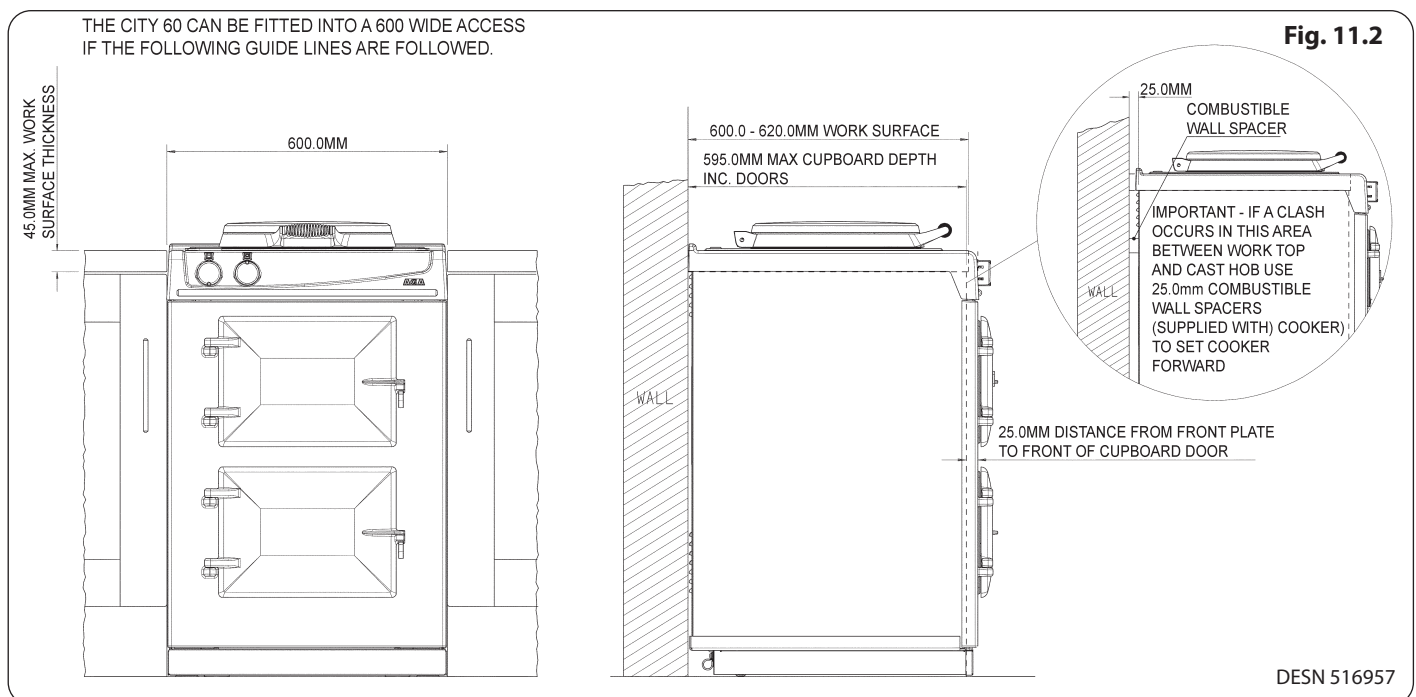
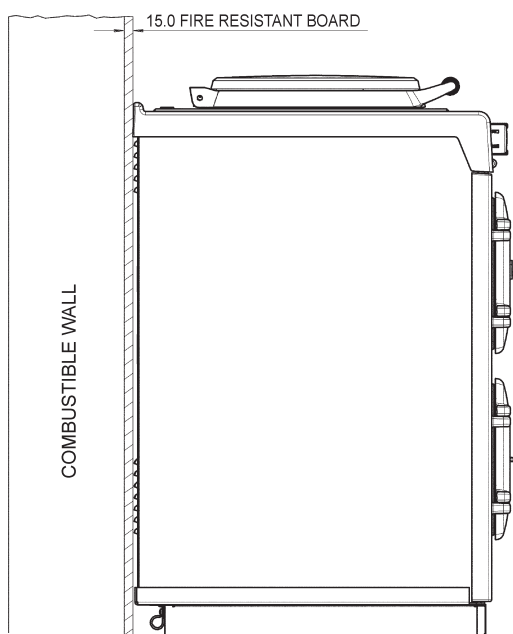

Fig. 11.3
COMBUSTIBLE WALL FITTING
USING FIRE RESISTANT BOARD



DESN 516959

Combustible Rear Walls

Since this appliance can be used continuously, please take note of the **IMPORTANT INSTRUCTIONS**.

Where the rear wall is constructed of combustible materials (such as all-timber or stud wall partitions and batoned plasterboard) these will require special wall heat protection measures.

Non-combustible insulation board as a protective cladding can be used behind the appliance of at least 15mm thick, such as Monolux or equivalent. This should be taken up to hotplate level (**Fig. 11.3**).

Alternatively the cooker can be spaced away from the wall to create an air gap, using the 25mm spacer brackets supplied with the cooker (**Fig. 11.4**).

Fig. 11.4

2-OFF SPACER BRACKETS
SUPPLIED WITH THE COOKER
FITTED TO BACK PANEL

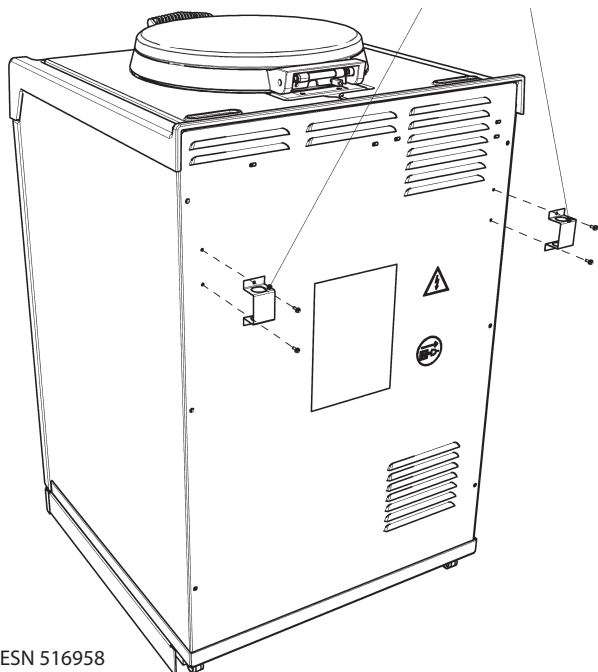

DESN 516958

The air gap must be left open and **NOT** blocked off across the top edge (**Fig. 11.5**).

SPECIAL NOTE: Ensure that unprotected electric cabling or plastic services do not pass within or on the outside of the wall behind or directly above the appliance. This type of material can age prematurely when exposed to continuous higher temperature.

Other Clearances

A minimum clearance of 60mm is required above the raised insulating cover handle.

A minimum clearance of 1000mm must be available at the front of the appliance to enable it to be serviced.

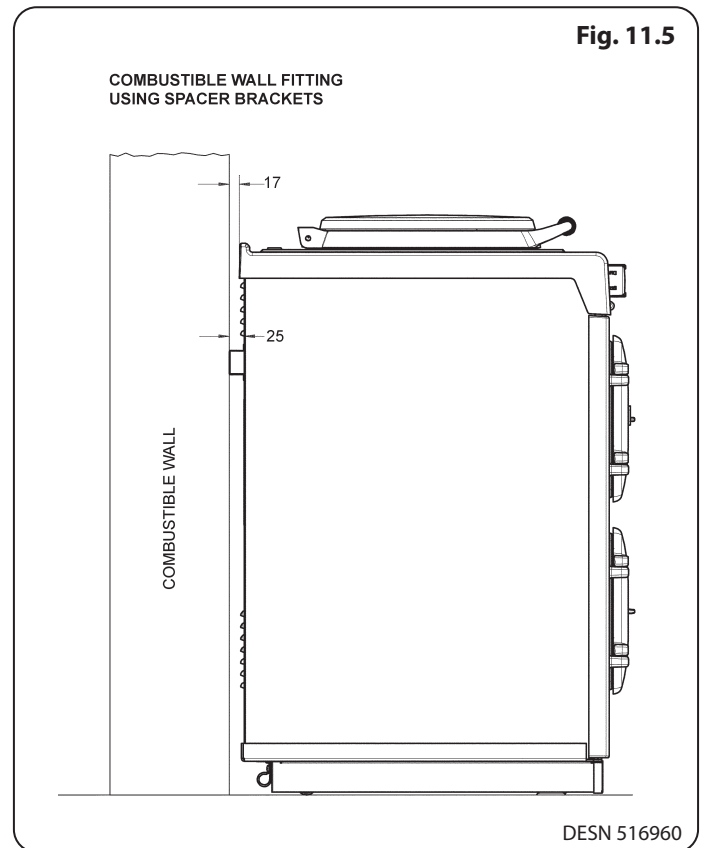

12. Electrical connection

- ⚠ WARNING: This appliance must be earthed.**
- ⚠ This appliance is designed for the voltage stated on the rating plate, which is situated behind the plinth cover.**
- ⚠ If the supply cord is damaged, it must be replaced by the manufacturer, its service agent or similarly qualified person to avoid a hazard.**

A 1PH 30 amp 230V or 3PH 400V minimum 16A per phase ~ 50 Hz fused electrical supply is required adjacent to the appliance. External wiring to the unit must be installed using the mains cable provided, in accordance with the current wiring regulations and any local regulations which apply. If the cable is shortened, new ferrules must be fitted to the stripped conductors.

The method of connection to the mains electricity supply must facilitate complete electrical isolation of the appliance, by a multi-pole switch, having a contact separation of at least 3 mm on all poles.

The isolator should not be positioned immediately above the cooker, but must be fitted within 2 metres of the appliance.

The isolator may be separate from the connection point.

The mains connection point must be accessible within the areas shown in **Fig. 12.1** and **Fig. 12.2** for cable routing options.

For 2 or 3 phase installations an optional adaptor kit must be obtained (Part No. AE4M231226).

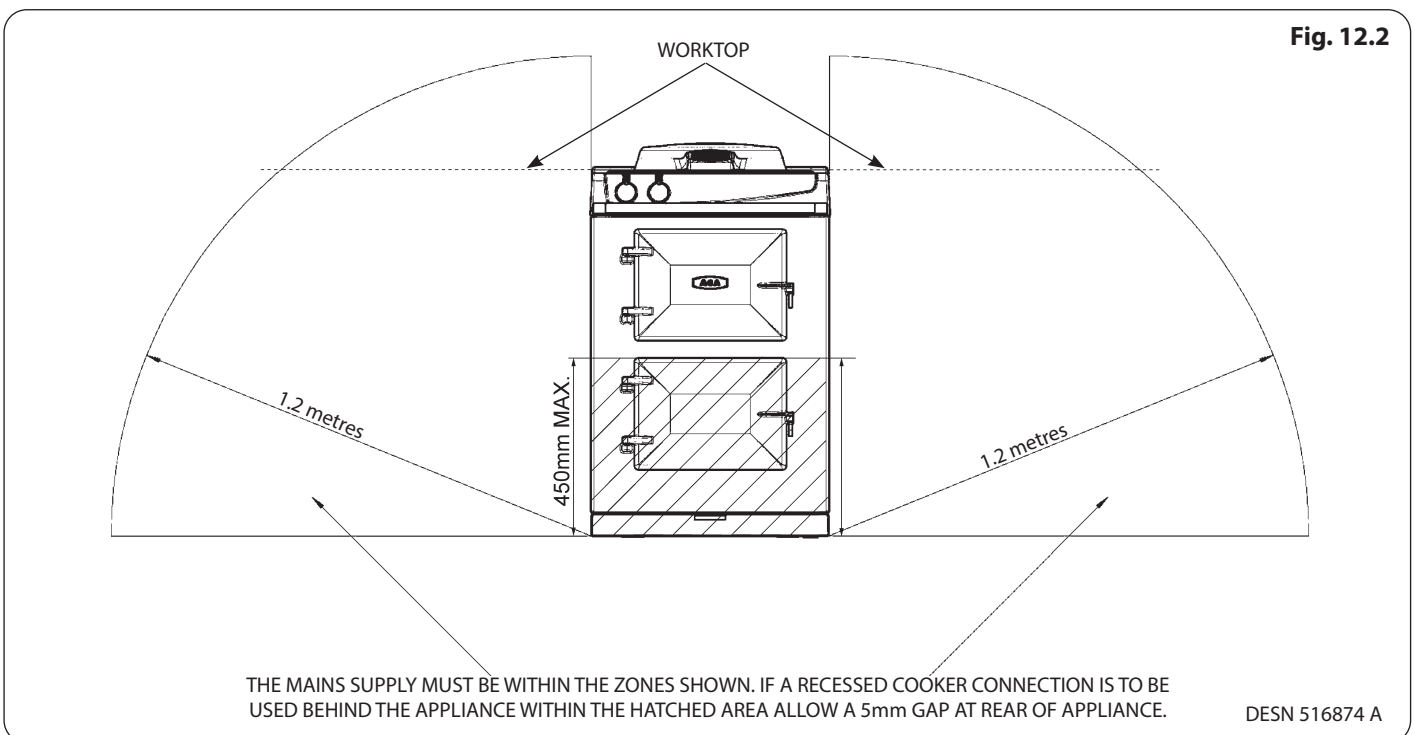
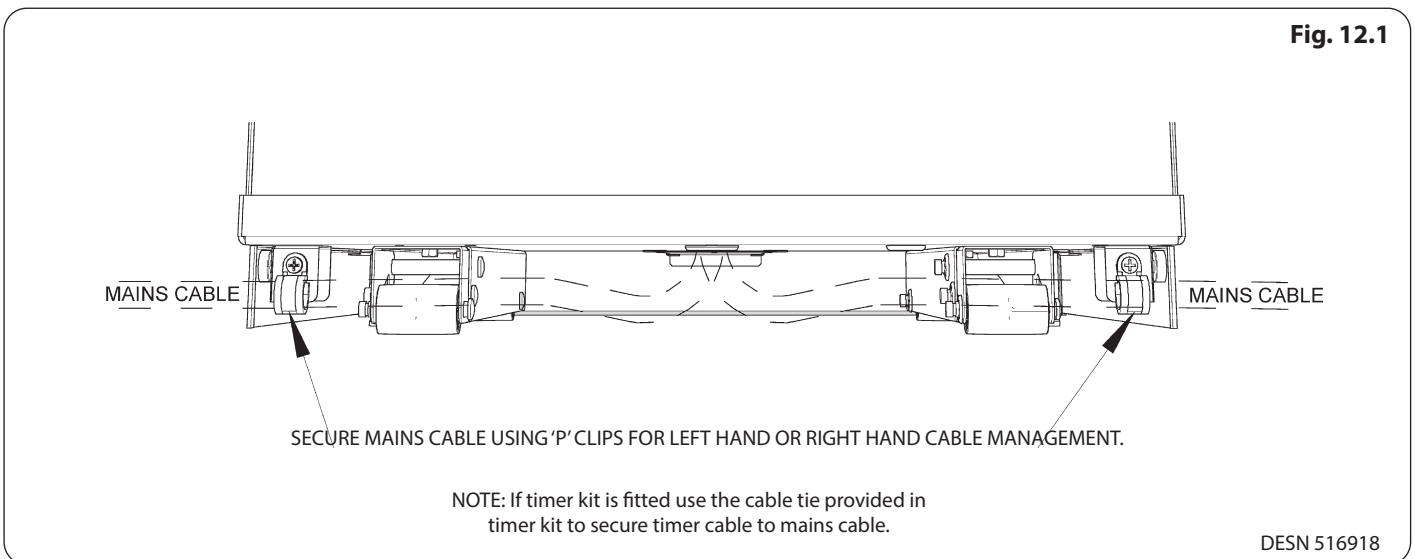

13. Control knob and handrail connection

Fig. 13.1

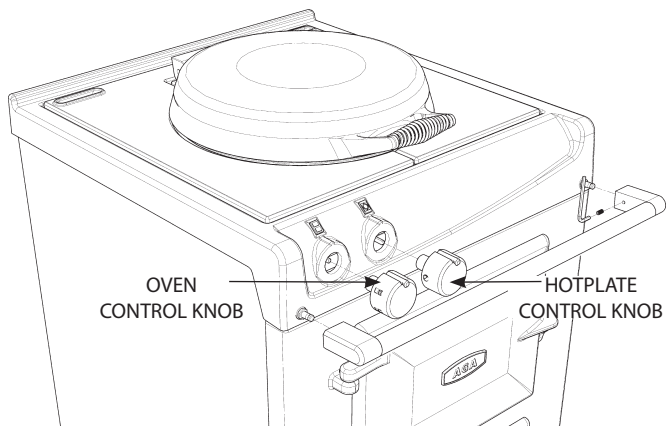

DESN 516875

Control Knob Location

Ensure control knobs are located onto spindles correctly, as shown in **(Fig. 13.1)**.

Handrail Location - AGA 60 (Traditional)

Locate handrail onto spindle, lock into position with grub screws (located on the inside of the bracket).

14. Circuit diagram

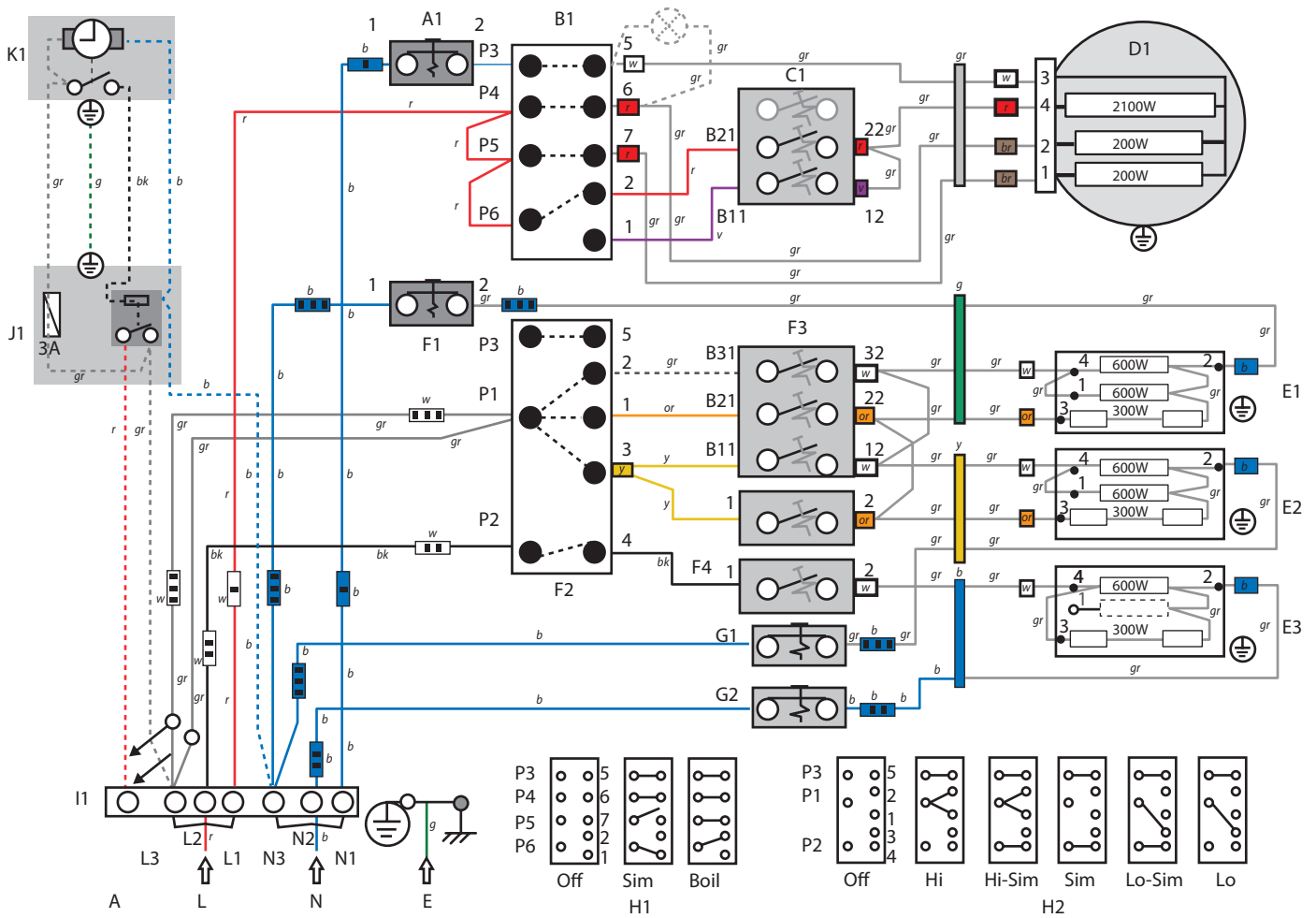

Code	Description
A1	Hotplate overheat thermostat
B1	Hotplate Selector Switch
C1	Hotplate Thermostat
D1	Hotplate Element
E1	Upper Top Element
E2	Upper Oven Base Element
E3	Upper Oven Base Element
F1	Upper Oven Overheat Thermostat
F2	Oven Selector Switch
F3	Upper Oven Thermostat

Code	Description
F4	Lower Oven Thermostat
G1	Upper Oven Overheat Switch
G2	Lower Oven Overheat Switch
H1	Hotplate Selector Setting
H2	Oven Selector Setting
I1	Mount Terminal Bracket
J1	Relay Box
K1	Upper Oven Timer

Code	Colour
b	Blue
br	Brown
bk	Black
or	Orange
r	Red
v	Violet
w	White
y	Yellow
g/y	Green/yellow
gr	Grey

15. Checklist

Hand these instructions to the user for retention, and instruct in the safe operation of the appliance.		
Serial No.		Tick Box / Not Applicable (N/A)
Check hotplate lid and setting		
Check oven door seals, adjust door alignment if necessary.		
Baking and Simmering oven rope seals MUST have a gap between the door hinges. The Roasting Oven is fitted with a continuous seal.		
Ensure any plastic film is removed from the inside of the oven doors.		
After 30 minutes, check hotplate temperatures (approx).		
1. Simmerspot (200 - 250°C)		
then hotplate to boiling, after 15 minutes check temperature		
2. Hotspot (330 - 380°C)		
Turn on roasting and simmering oven, set hotplate to simmer. Raise hotplate lid to avoid staining.		
Guide customer through the Users Instructions of the appliance, offering best practices on oven maintenance, energy usage, enamel cleaning (boiled vegetable water staining on enamel etc.)		
Engineer's Signature Date		



AGA CLOUD, THE FIRST AGA RECIPE APP

Download AGA Cloud to view a host of delicious step-by-step recipes tailored to your AGA appliance.

Available only in the United Kingdom and Ireland.



With AGA Rangemaster's policy of continuous product improvement, the Company reserves the right to change specifications and make modifications to the appliances described and illustrated at any time.



Manufactured By
AGA Rangemaster
Station Road
Ketley Telford
Shropshire TF1 5AQ
England

www.agaliving.com
www.agacookshop.co.uk

